



Zone Valve Engineering & Installation Reference Notes

Locating & Mounting

Electric valves, like all other mechanical equipment, should be installed with a degree of accessibility to enable quick and economical servicing or replacement. On high rise buildings, use reducing valves on branch lines on lower floors.

Note For Fan Coil Installations

Valve motor and gear train will not function properly when wet. Motor housing must be protected from drippage. Motor housing need not be protected from condensation on its attached valve body when installation in horizontal piping, if valve is positioned within 85° of upright position, (See Fig. 1). When mounted in vertical piping, motor housing must be protected from drippage.

Valves with Sweat Connections

Prior to soldering, place valve in manually open position by moving lever to retaining notch. Ends of water supply tubing must be thoroughly clean for a minimum distance of 25 mm from end.

Instructions for Sweating

Use only lead or tin based solder with melting point below 300 °C. Do not overheat valve body.

CAUTION

This valve is not intended for use with systems that require frequent mark-up water. Systems which are primarily for domestic hot water supply are sometimes also used for heating purposes. In this type of application, the large volume of mark-up or fresh water will contain dissolved oxygen and minerals which can cause early valve failure.

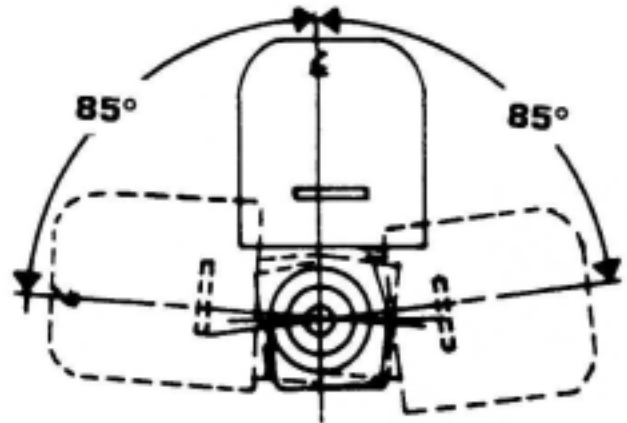

Figure 1 Mounting position

Normal Use

All zone valves designed to provide a useful life of at least 100,000 cycles. A cycle being defined as operation of the zone valve to its normal stop and then allowing it to return its normal position.

Manual Operating Lever

When valves are placed in the open position with the manual lever, the paddle is removed from the seat or port. This must be done prior to soldering sweat valves. Move the lever slowly to the open position and hold in the retaining notch until the gear is taken up by the return spring.

THE MANUAL LEVER WILL RESET TO THE AUTOMATIC POSITION THE FIRST TIME THE VALVE IS CYCLED ELECTRICALLY.

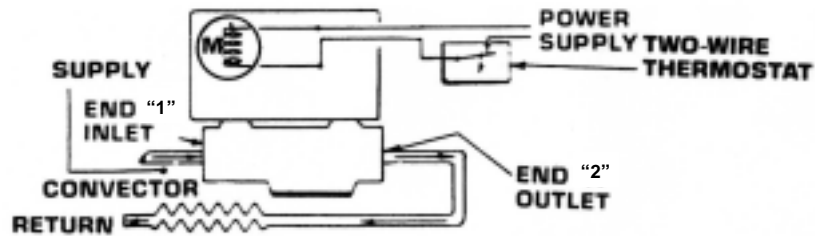

Two-way Valves

When installing **normally-closed** two-way valves, the flow direction is from end 1 to end 2. On **normally-open** valves, the flow is end 2 to end 1. In both cases, the valve closes **against** the flow of the fluid.

THREE-WAY VALVE

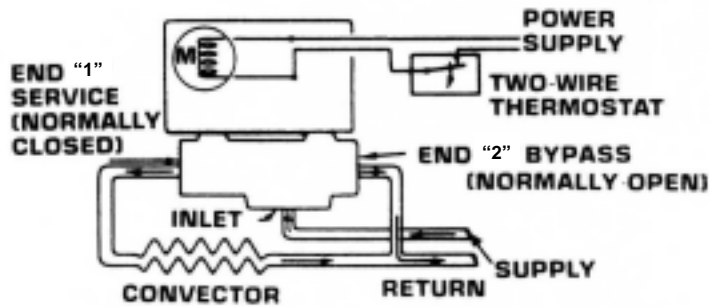

THREE-WAY VALVE WITH STRAP-ON CHANGE-OVER SWITCH

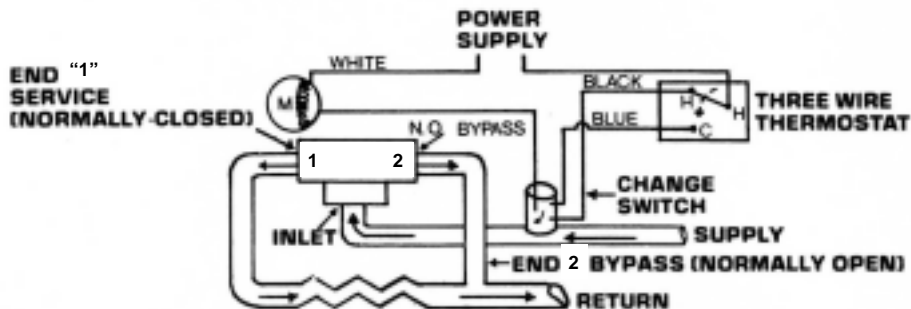

Three-way Valves

When installing normally-closed three-way diverting valves, end 1 is the service connection and end 2 is the by-pass connection. The inlet port is unmarked. On normally-open three-way valves, the service end is 2 and the by-pass end is 1. Port marking 1 and 2 are located on the bottom of the valve body.